

# PL2KA-S-(000X0)-RP

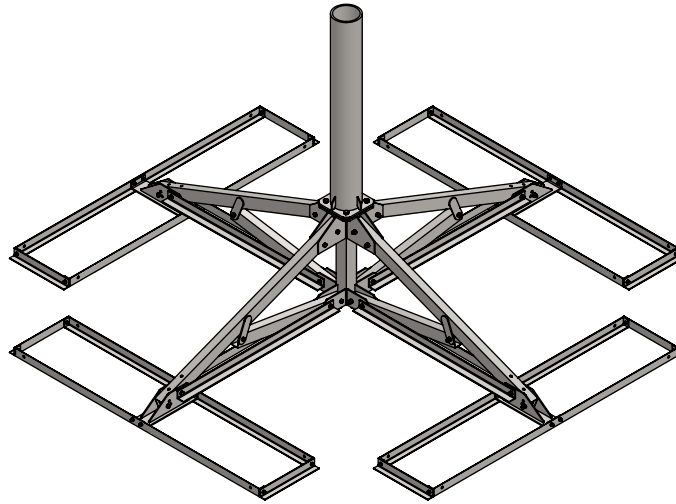

SYM	PART#	DESCRIPTION	QTY.	
1	AB1511(1/2X9)H	PL2 BASE, HDG	1	
2	AB1512AHD	PL2/VL4 ARM ASS'Y, HDG	4	
3	AB1136AHD	PL2/VL4 BRACE TUBE, HDG	4	
4	AB1756HD	PL2 FOOT ASS'Y, HDG	4	
5	AS REQ'D	MAST ASS'Y, HDG	1	
6	H1-0750-200	3/4"x2" BOLT GR.5, Z/P	4	HDWE- MH7
7	H4-0750LW	3/4" SPLIT LOCKWASHER, Z/P	4	
8	H2-0750HN	3/4" NUT , Z/P	4	
9	H1-0500-350	1/2" x 3-1/2" BOLT GR.5, Z/P	28	HDWE 28X350
10	H4-0500LW	1/2" SPLIT LOCKWASHER, Z/P	28	
11	H2-0500HN	1/2" NUT, Z/P	28	
12	AB1119BHD	6' BALLAST ANGLE(1.5x2L), HDG	8	HDWE-BT QTY.2
13	AB1126BHD	16" SIDE PAD (1.5x2L), HDG	8	
14	H1-0375-100	3/8" x 1" BOLT GR.5, Z/P	32	
15	H4-0375LW	3/8" SPLITLOCKWASHER, Z/P	32	
16	H2-0375HN	3/8" HEX NUT, Z/P	32	
17	AB1519(PL2)HD	PL2 KA BRACE ANGLE .18x2x2Lx45.88", HDG	8	
		RUBBER PAD 18"x48"	8	
		PALLET	1	

**PROPRIETARY AND CONFIDENTIAL**

THE INFORMATION CONTAINED IN THIS DRAWING IS THE SOLE PROPERTY OF BAIRD SUPPORTING SYSTEMS. ANY REPRODUCTION IN PART OR AS A WHOLE WITHOUT THE WRITTEN PERMISSION OF BAIRD SUPPORTING SYSTEMS IS PROHIBITED.



WWW.BAIRD MOUNTS.COM

UNLESS OTHERWISE SPECIFIED:

DIMENSIONS ARE IN INCHES  
 TOLERANCES:  
 FRACTIONAL ±  
 ANGULAR: MACH ± BEND ±  
 TWO PLACE DECIMAL ±  
 THREE PLACE DECIMAL ±

DO NOT SCALE DRAWING

**BAIRD MOUNTING SYSTEMS**

WATERLOO, IA 50703  
 PHONE: 319-233-3561  
 SALES@BAIRDMOUNTS.COM

TITLE:  
 PL2KA, SINGLE TRAY, MAST, PAD

DRAWN BY JK	DATE 1/21/22
MATERIAL STEEL	FINISH HDG
DWG. PURPOSE INST	SHEET 1
	SCALE -
PART. NO. PL2KA-S-(000X0)	
DWG. NO. PL2KA-S-(000X0)-RP INST.	

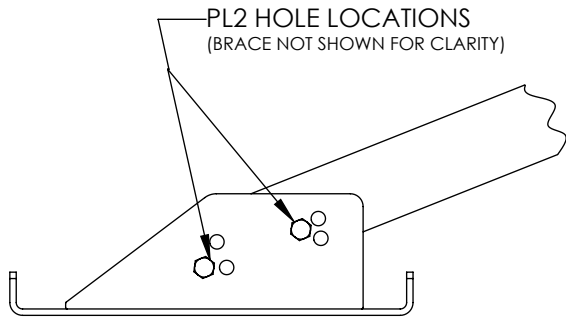

PL2 ARM TO FOOT DETAIL

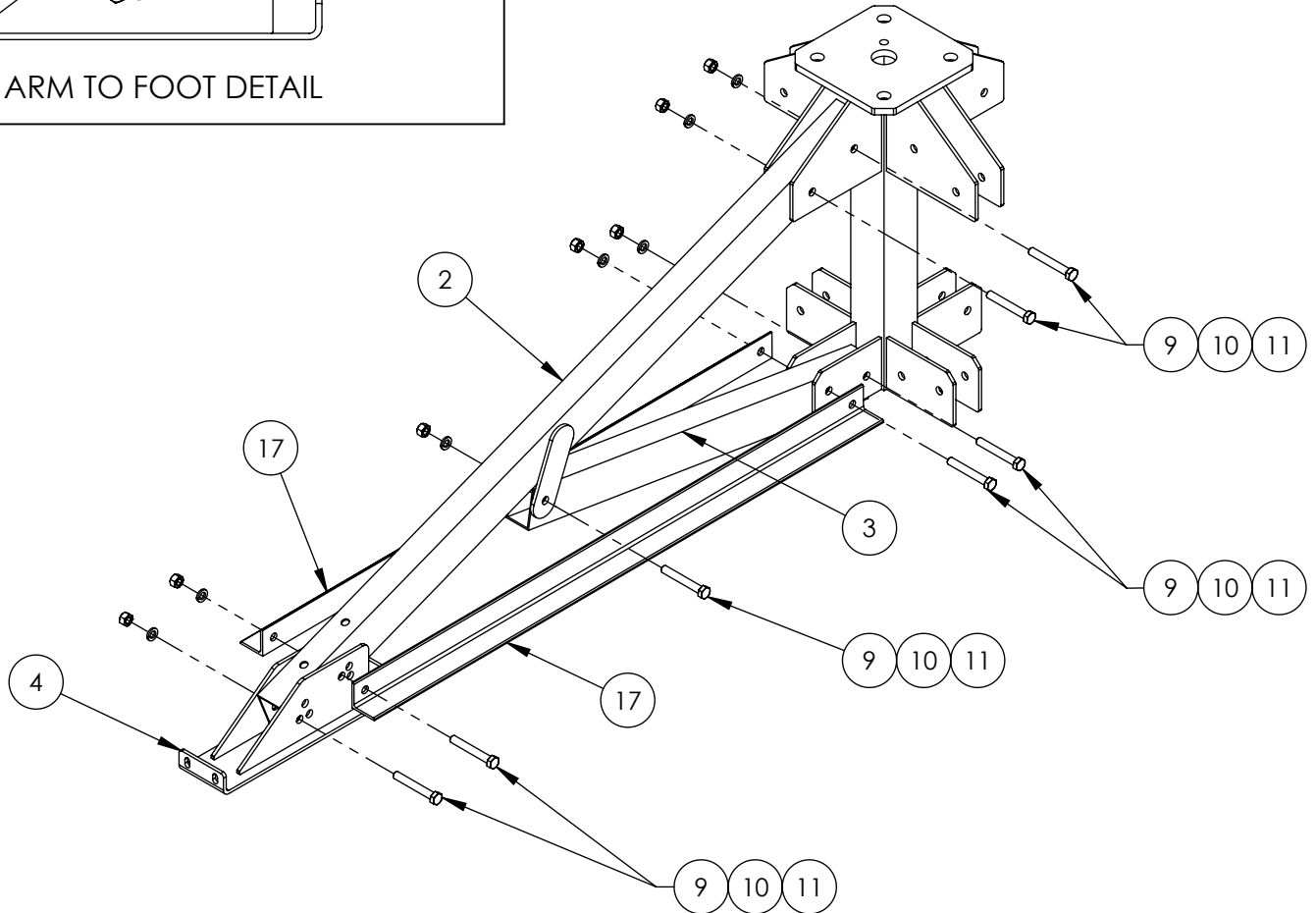

Begin assembling the mount by attaching an arm ass'y(#2) to the upper fins using (2) 1/2"x3-1/2" bolts (#9), lockwashers(#10) and nuts(#11). Next, attach the short brace tube(#3) & KA brace angles (#17) to the lower fins on the base using (2) 1/2"x3-1/2" bolts, lockwashers and nuts. Attach the brace tube to the links on the long arm using (1)1/2"x3-1/2" bolts, lockwashers and nuts. The foot ass'y(#4) is attached to the arm using (2) 1/2"x3-1/2" bolts, lockwashers and nuts, also attach the KA Brace angle(#17) at this step (see diagram above).Repeat this procedure for the three remaining sides of the mount.

It may help to place the mount on a 3" tall block to keep pressure off the arms while aligning the bolt holes. **Do not tighten hardware until assembly is complete and mount is in its final location.**

**PROPRIETARY AND CONFIDENTIAL**

THE INFORMATION CONTAINED IN THIS DRAWING IS THE SOLE PROPERTY OF BAIRD SUPPORTING SYSTEMS. ANY REPRODUCTION IN PART OR AS A WHOLE WITHOUT THE WRITTEN PERMISSION OF BAIRD SUPPORTING SYSTEMS IS PROHIBITED.



WWW.BAIRD MOUNTS.COM

UNLESS OTHERWISE SPECIFIED:

DIMENSIONS ARE IN INCHES  
 TOLERANCES:  
 FRACTIONAL ±  
 ANGULAR: MACH ± BEND ±  
 TWO PLACE DECIMAL ±  
 THREE PLACE DECIMAL ±

DO NOT SCALE DRAWING

**BAIRD MOUNTING SYSTEMS**

WATERLOO, IA 50703  
 PHONE: 319-233-3561  
 SALES@BAIRDMOUNTS.COM

TITLE:  
 PL2KA, SINGLE TRAY, MAST, PAD

DRAWN BY JK	DATE 1/21/22
MATERIAL STEEL	FINISH HDG
DWG. PURPOSE INST	SHEET 2
PART. NO. PL2KA-S-(000X0)	SCALE -
DWG. NO. PL2KA-S-(000X0)-RP INST.	

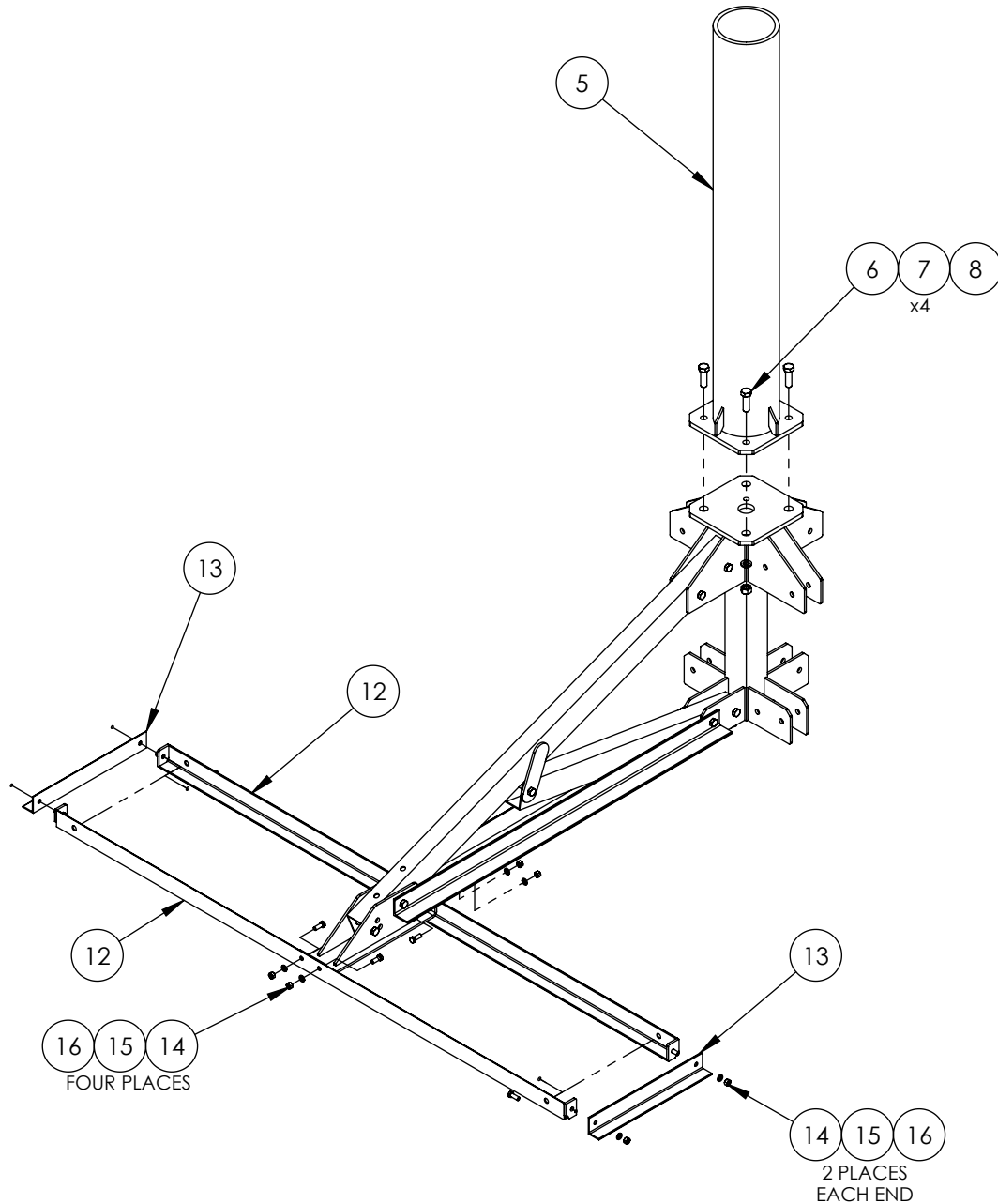

Assemble the ballast trays, as shown above, using two 6' ballast angles (#12), two 16" side pads (#13) and four 3/8"x1" bolts(#14), nuts(#16) and lockwashers(#15). Attach the foot assy to the ballast tray using four 3/8"x1" bolts, nuts and lockwashers. Repeat the process for each leg. Attach mast assy(#5) to the mount with four 3/4"x2" Bolts (#6), lockwashers(#7) and nuts(#8).

**PROPRIETARY AND CONFIDENTIAL**

THE INFORMATION CONTAINED IN THIS DRAWING IS THE SOLE PROPERTY OF BAIRD SUPPORTING SYSTEMS. ANY REPRODUCTION IN PART OR AS A WHOLE WITHOUT THE WRITTEN PERMISSION OF BAIRD SUPPORTING SYSTEMS IS PROHIBITED.



WWW.BAIRD MOUNTS.COM

**UNLESS OTHERWISE SPECIFIED:**

DIMENSIONS ARE IN INCHES  
 TOLERANCES:  
 FRACTIONAL ±  
 ANGULAR: MACH ± BEND ±  
 TWO PLACE DECIMAL ±  
 THREE PLACE DECIMAL ±

DO NOT SCALE DRAWING

**BAIRD MOUNTING SYSTEMS**

WATERLOO, IA 50703  
 PHONE: 319-233-3561  
 SALES@BAIRDMOUNTS.COM

TITLE:  
 PL2KA, SINGLE TRAY, MAST, PAD

DRAWN BY JK	DATE 1/21/22
MATERIAL STEEL	FINISH HDG
DWG. PURPOSE INST	SHEET 3
	SCALE -
PART. NO. PL2KA-S-(000X0)	
DWG. NO. PL2KA-S-(000X0)-RP INST.	