

MATERIAL

SYM	PART #	DESCRIPTION	QTY.
1	AB1620(4)HD	B44 SUPPORT TUBE ASSY, HDG	1
2	AB1624(48)HD	4' B4-4X4 BALLAST ANGLE, HDG	4
3	AB1425HD	16" SIDE PAD, HDG	4
4	AS REQ'D	MAST ASSY (DIAMETER & LENGTH AS REQUIRED), HDG	1
5	AB1622RL(38.7)HD	B4-4X4 RH REAR BRACE 38.7" LONG, HDG	2
6	AB1621RHHD	B4 RH SIDE BRACE 28.25" LONG, HDG	1
7	AB1621LHHD	B4 LH SIDE BRACE 28.25" LONG, HDG	1
8	H1-0375-100	3/8"x1" BOLT GR.5, Z/P	18
9	H1-0375-400TB	3/8" x 4" TAP BOLT(FULL THREAD) GR.5, Z/P	3
10	H2-0375HN	3/8" NUT, Z/P	19
11	H2-0375WN	3/8" WHIZ-LOCK NUT, Z/P	2
12	H4-0375LW	3/8" SPLIT-LOCKWASHER, Z/P	19
13	H3-0375FW	3/8" USS FLATWASHER, Z/P	2
14		RUBBER PAD 16"x52"	2

HARDWARE KIT
p/n: HDWE-B4

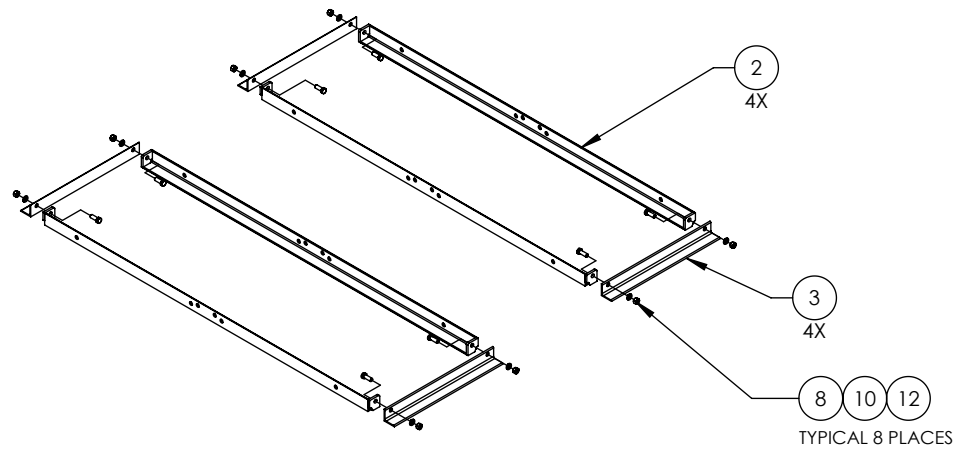

ASSEMBLE THE TWO BALLAST TRAYS (AS SHOWN ABOVE). EACH BALLAST TRAY CONSISTS OF TWO 4' BALLAST ANGLES(#2) AND TWO SIDE PADS(#3). ASSEMBLE EACH TRAY USING FOUR 3/8"x1" BOLTS(#8), NUTS(#10) AND LOCKWASHERS(#12)

PROPRIETARY AND CONFIDENTIAL

THE INFORMATION CONTAINED IN THIS DRAWING IS THE SOLE PROPERTY OF BAIRD SUPPORTING SYSTEMS. ANY REPRODUCTION IN PART OR AS A WHOLE WITHOUT THE WRITTEN PERMISSION OF BAIRD SUPPORTING SYSTEMS IS PROHIBITED.



WWW.BAIRD MOUNTS.COM

UNLESS OTHERWISE SPECIFIED:

DIMENSIONS ARE IN INCHES
TOLERANCES:
FRACTIONAL ±
ANGULAR: MACH ± BEND ±
TWO PLACE DECIMAL ±
THREE PLACE DECIMAL ±

DO NOT SCALE DRAWING

BAIRD MOUNTING SYSTEMS

WATERLOO, IA 50703
PHONE: 319-233-3561
SALES@BAIRDMOUNTS.COM

TITLE:
B4-4X4DRB, (000)x(0)B4 MAST, PAD

DRAWN BY JK	DATE 10/26/18
MATERIAL -	FINISH -
DWG. PURPOSE INST	SHEET 1
	SCALE -
PART. NO. B44DRB-(000)X(0)-R	
DWG. NO. B44DRB-(000)X(0)-R	

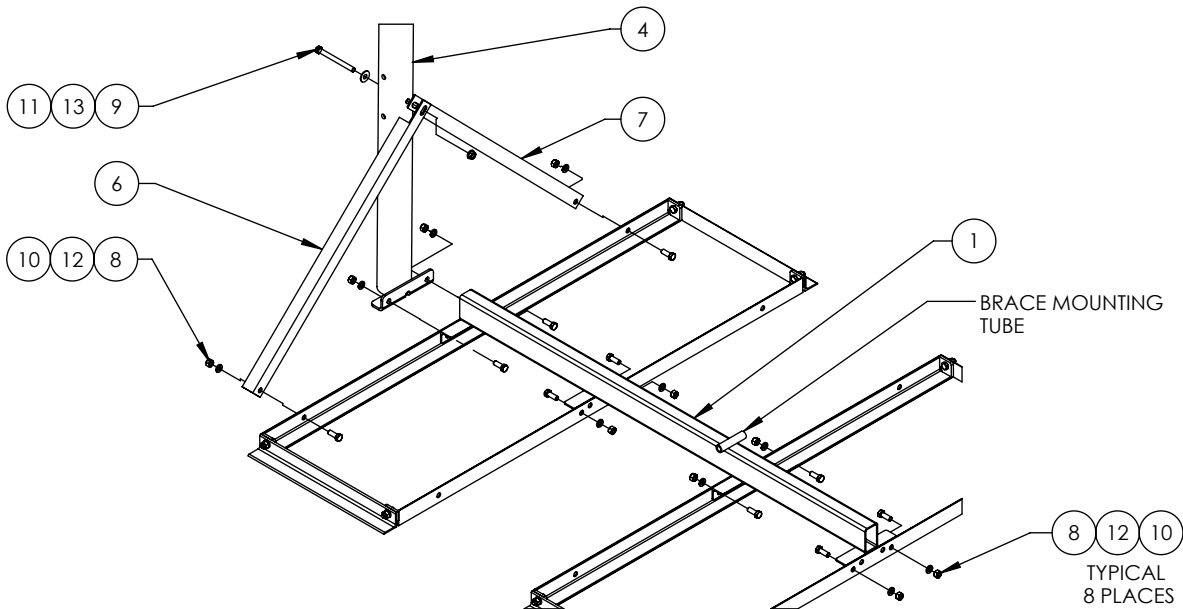

ATTACH THE SUPPORT TUBE ASS'Y(#1) TO THE BALLAST TRAYS, AS SHOWN ABOVE, USING (2) 3/8"x1" BOLTS, NUTS AND LOCKWASHERS AT EACH ANGLE. NOTE, THE MOUNTING ANGLES FIT ON THE INSIDE OF THE 4' BALLAST TRAYS. THE MAST (#4) IS ATTACHED AT THE END OF THE MOUNT AWAY FROM THE BRACE MOUNTING TUBE.

ATTACH THE RH SIDE BRACE(#6) & THE LH SIDE BRACE(#7) TO THE MAST USING A 3/8"x4" FULL-THREAD BOLT, FLATWASHER & WHIZLOCK NUT. NOTE, THE NOTCHED ENDS OF EACH BRACE ATTACH AT THE MAST. SECURE THE OTHER END OF EACH BRACE TO THE BALLAST TRAY USING A 3/8"x1" BOLT, NUT & LOCKWASHER.

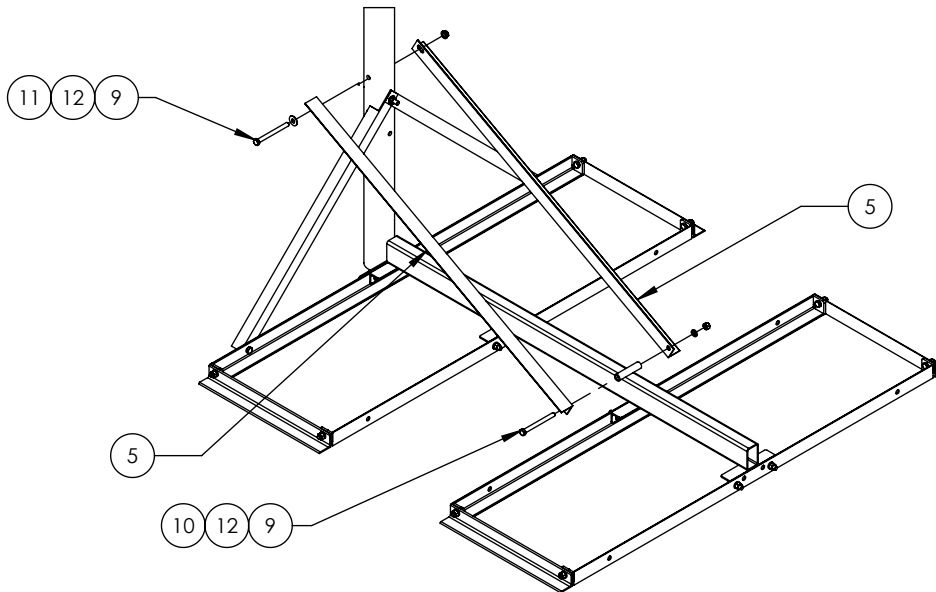

FASTEN THE TWO REAR BRACES (#5) TO THE MAST USING A 3/8"x4" FULL-THREAD BOLT, FLATWASHER AND WHIZ-LOCK NUT. NOTE: THE SLOTTED HOLE OF EACH REAR BRACE ATTACHES AT THE MAST. THE OTHER END OF EACH BRACE ATTACHES TO THE REAR BRACE MOUNTING TUBE USING A 3/8"x4" FULL-THREAD BOLT, LOCKWASHER AND NUT.

PROPRIETARY AND CONFIDENTIAL

THE INFORMATION CONTAINED IN THIS DRAWING IS THE SOLE PROPERTY OF BAIRD SUPPORTING SYSTEMS. ANY REPRODUCTION IN PART OR AS A WHOLE WITHOUT THE WRITTEN PERMISSION OF BAIRD SUPPORTING SYSTEMS IS PROHIBITED.



WWW.BAIRD MOUNTS.COM

UNLESS OTHERWISE SPECIFIED:

DIMENSIONS ARE IN INCHES
 TOLERANCES:
 FRACTIONAL ±
 ANGULAR: MACH ± BEND ±
 TWO PLACE DECIMAL ±
 THREE PLACE DECIMAL ±

DO NOT SCALE DRAWING

BAIRD MOUNTING SYSTEMS

WATERLOO, IA 50703
 PHONE: 319-233-3561
 SALES@BAIRD MOUNTS.COM

TITLE:
 B4-4X4DRB, (000)X(0)B4 MAST, PAD

DRAWN BY JK	DATE 10/26/18
MATERIAL -	FINISH -
DWG. PURPOSE INST	SHEET 2
PART. NO. B44DRB-(000)X(0)-R	SCALE -
DWG. NO. B44DRB-(000)X(0)-R	