

PART NO.	MAST DIAMETER	WEIGHT
B46LBK-288X8	2.88"OD	140 lbs.

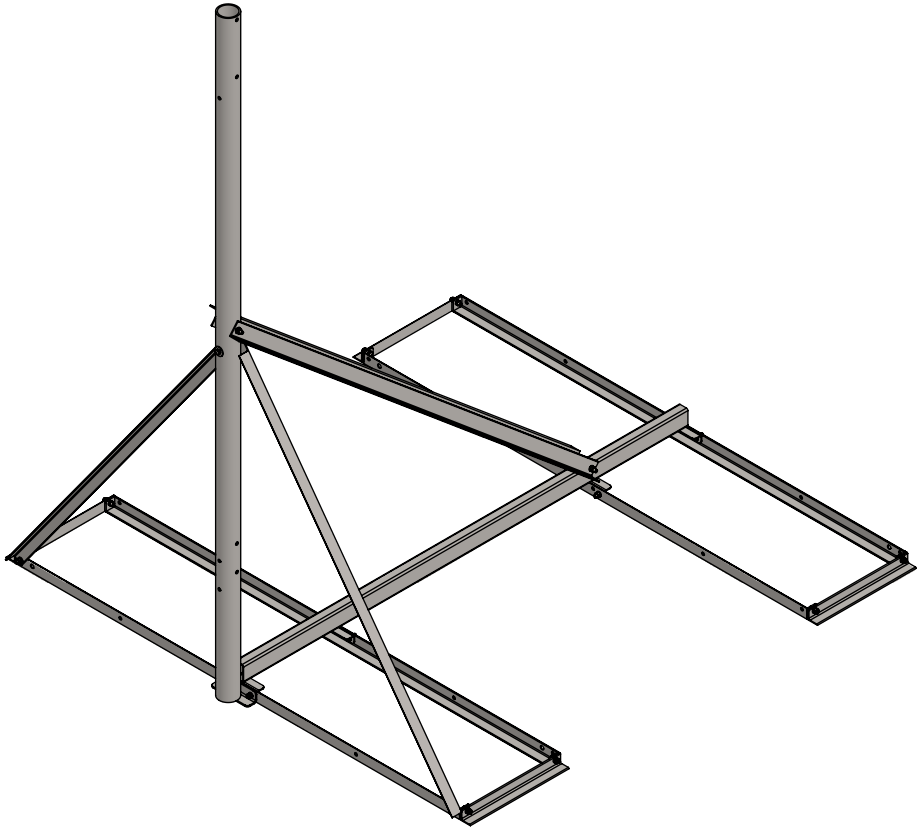

PROPRIETARY AND CONFIDENTIAL
 THE INFORMATION CONTAINED IN THIS DRAWING IS THE SOLE PROPERTY OF BAIRD SUPPORTING SYSTEMS. ANY REPRODUCTION IN PART OR AS A WHOLE WITHOUT THE WRITTEN PERMISSION OF BAIRD SUPPORTING SYSTEMS IS PROHIBITED.



WWW.BAIRD MOUNTS.COM

UNLESS OTHERWISE SPECIFIED:
 DIMENSIONS ARE IN INCHES
 TOLERANCES:
 FRACTIONAL ±
 ANGULAR: MACH ± BEND ±
 TWO PLACE DECIMAL ±
 THREE PLACE DECIMAL ±

DO NOT SCALE DRAWING

BAIRD MOUNTING SYSTEMS

WATERLOO, IA 50703
 PHONE: 319-233-3561
 SALES@BAIRD MOUNTS.COM

DESCRIPTION:
 B4-6X6 LONG BRACE KIT, 2.88"ODx8' MAST

DRAWN BY JK	DATE 05/12/16	
MATERIAL STEEL	FINISH HDG	
DWG. PURPOSE CUSTOMER	SHEET 1 OF 2	SCALE -
PART. NO. B46LBK-288X8		
DWG. NO. B46LBK-288X8		

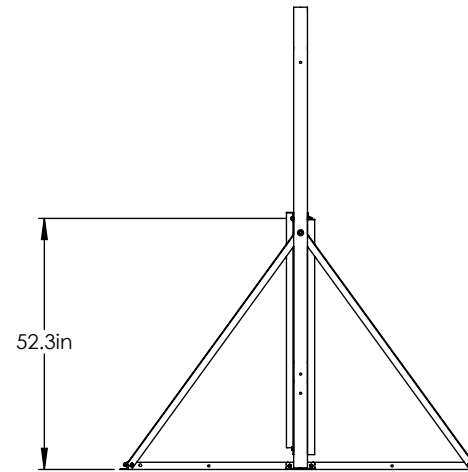
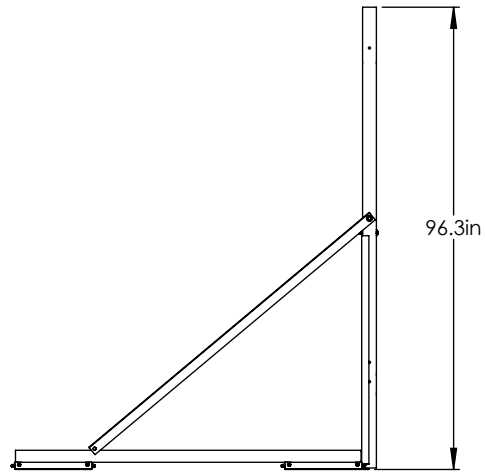
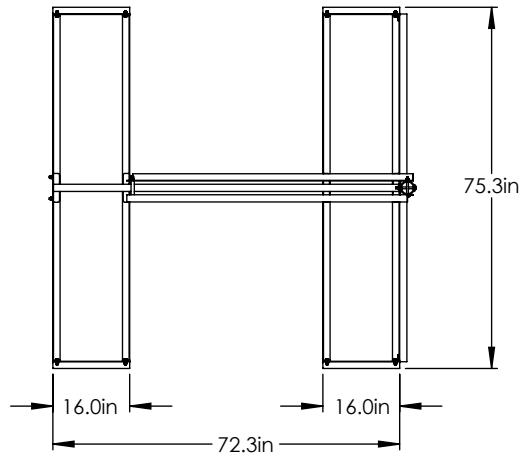

PROPRIETARY AND CONFIDENTIAL
 THE INFORMATION CONTAINED IN THIS DRAWING IS THE SOLE PROPERTY OF BAIRD SUPPORTING SYSTEMS. ANY REPRODUCTION IN PART OR AS A WHOLE WITHOUT THE WRITTEN PERMISSION OF BAIRD SUPPORTING SYSTEMS IS PROHIBITED.



WWW.BAIRDMOUNTS.COM

UNLESS OTHERWISE SPECIFIED:
 DIMENSIONS ARE IN INCHES
 TOLERANCES:
 FRACTIONAL ±
 ANGULAR: MACH ± BEND ±
 TWO PLACE DECIMAL ±
 THREE PLACE DECIMAL ±

DO NOT SCALE DRAWING

BAIRD MOUNTING SYSTEMS

WATERLOO, IA 50703
 PHONE: 319-233-3561
 SALES@BAIRDMOUNTS.COM

DESCRIPTION:
 B4-6X6 LONG BRACE KIT, 2.88"ODx8' MAST

DRAWN BY JK	DATE 05/12/16	
MATERIAL STEEL	FINISH HDG	
DWG. PURPOSE CUSTOMER	SHEET 2OF2	SCALE -
PART. NO. B46LBK-288X8		
DWG. NO. B46LBK-288X8		

PART NO.	MAST DIAMETER	WEIGHT
B46LBK-288X10	2.88"OD	151 lbs.



PROPRIETARY AND CONFIDENTIAL
 THE INFORMATION CONTAINED IN THIS DRAWING IS THE SOLE PROPERTY OF BAIRD SUPPORTING SYSTEMS. ANY REPRODUCTION IN PART OR AS A WHOLE WITHOUT THE WRITTEN PERMISSION OF BAIRD SUPPORTING SYSTEMS IS PROHIBITED.



WWW.BAIRD MOUNTS.COM

UNLESS OTHERWISE SPECIFIED:
 DIMENSIONS ARE IN INCHES
 TOLERANCES:
 FRACTIONAL ±
 ANGULAR: MACH ± BEND ±
 TWO PLACE DECIMAL ±
 THREE PLACE DECIMAL ±

DO NOT SCALE DRAWING

BAIRD MOUNTING SYSTEMS

WATERLOO, IA 50703
 PHONE: 319-233-3561
 SALES@BAIRD MOUNTS.COM

DESCRIPTION:
 B4-6X6 LONG BRACE KIT, 2.88ODx10' MAST

DRAWN BY JK	DATE 05/12/16	
MATERIAL STEEL	FINISH HDG	
DWG. PURPOSE CUSTOMER	SHEET 1OF2	SCALE -
PART. NO. B46LBK-288X10		
DWG. NO. B46LBK-288X10		

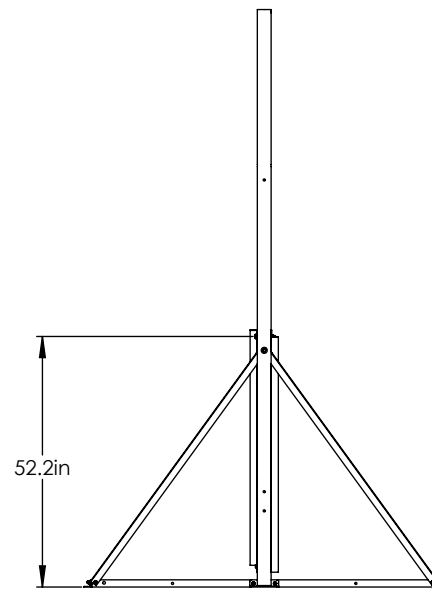
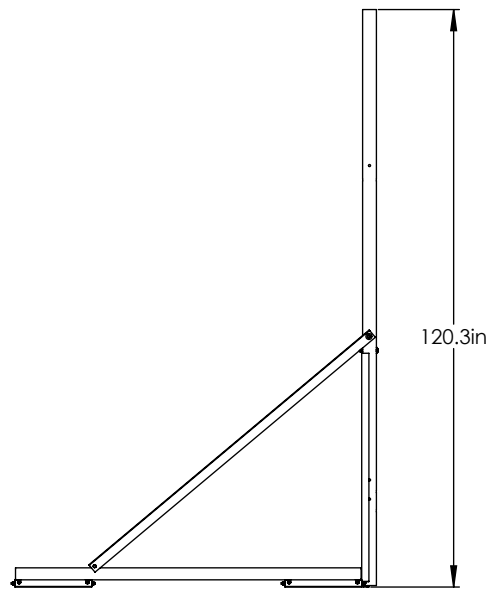
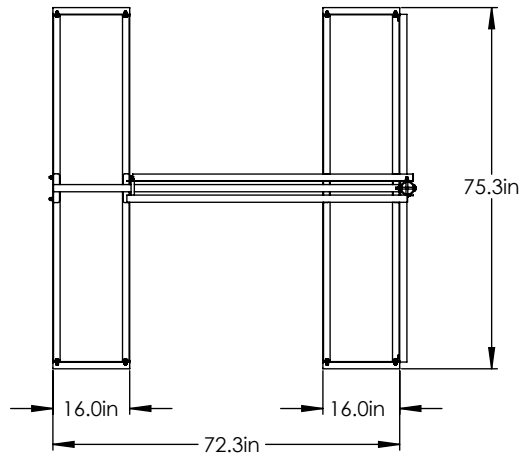

PROPRIETARY AND CONFIDENTIAL
 THE INFORMATION CONTAINED IN THIS DRAWING IS THE SOLE PROPERTY OF BAIRD SUPPORTING SYSTEMS. ANY REPRODUCTION IN PART OR AS A WHOLE WITHOUT THE WRITTEN PERMISSION OF BAIRD SUPPORTING SYSTEMS IS PROHIBITED.



WWW.BAIRD MOUNTS.COM

UNLESS OTHERWISE SPECIFIED:
 DIMENSIONS ARE IN INCHES
 TOLERANCES:
 FRACTIONAL ±
 ANGULAR: MACH ± BEND ±
 TWO PLACE DECIMAL ±
 THREE PLACE DECIMAL ±

DO NOT SCALE DRAWING

BAIRD MOUNTING SYSTEMS

WATERLOO, IA 50703
 PHONE: 319-233-3561
 SALES@BAIRD MOUNTS.COM

DESCRIPTION:
 B4-6X6 LONG BRACE KIT, 2.88ODx10' MAST

DRAWN BY JK	DATE 05/12/16	
MATERIAL STEEL	FINISH HDG	
DWG. PURPOSE CUSTOMER	SHEET 2OF2	SCALE -
PART. NO. B46LBK-288X10M		
DWG. NO. B46LBK-288X10		