

SYM	PART NO.	DESCRIPTION	QTY.
1	AB5940HD	AWM MOUNTING ANGLE FORMED 16", HDG	2
2	HUB-50X300X500HDG	1/2" DIA.x3"Wx5"D UBOLT, HDG	2
3	H2-0500HN2HHDG	1/2" NUT 2H, HDG	4
4	H4-0500LWHDG	1/2" SPLITLOCKWASHER, HDG	4
5	H3-0500FWHDG	1/2" FLATWASHER, HDG	4

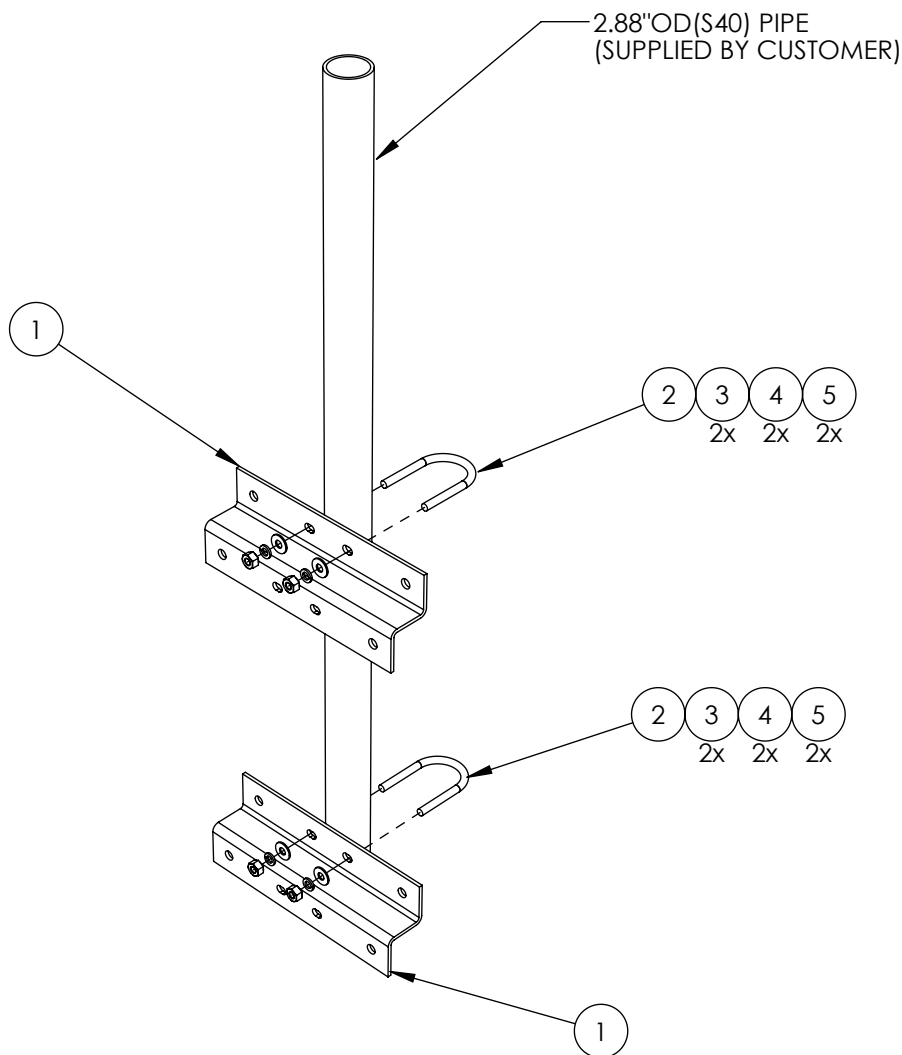

110416 CHANGED TO FORMED ANGLE

PROPRIETARY AND CONFIDENTIAL

THE INFORMATION CONTAINED IN THIS DRAWING IS THE SOLE PROPERTY OF BAIRD SUPPORTING SYSTEMS. ANY REPRODUCTION IN PART OR AS A WHOLE WITHOUT THE WRITTEN PERMISSION OF BAIRD SUPPORTING SYSTEMS IS PROHIBITED.



WWW.BAIRD MOUNTS.COM

UNLESS OTHERWISE SPECIFIED:

DIMENSIONS ARE IN INCHES
 TOLERANCES:
 FRACTIONAL ±
 TWO PLACE DECIMAL ±
 THREE PLACE DECIMAL ±

DO NOT SCALE DRAWING

BAIRD MOUNTING SYSTEMS

WATERLOO, IA 50703
 PHONE: 319-233-3561
 SALES@BAIRD MOUNTS.COM

TITLE:
 AWM-3OS16-288 INST

DRAWN BY JK	DATE 11/04/16
MATERIAL STEEL	FINISH HDG
DWG. PURPOSE INST	SHEET 1 OF 1
PART. NO. -	SCALE -
DWG. NO. AWM-3OS16-288 INST	

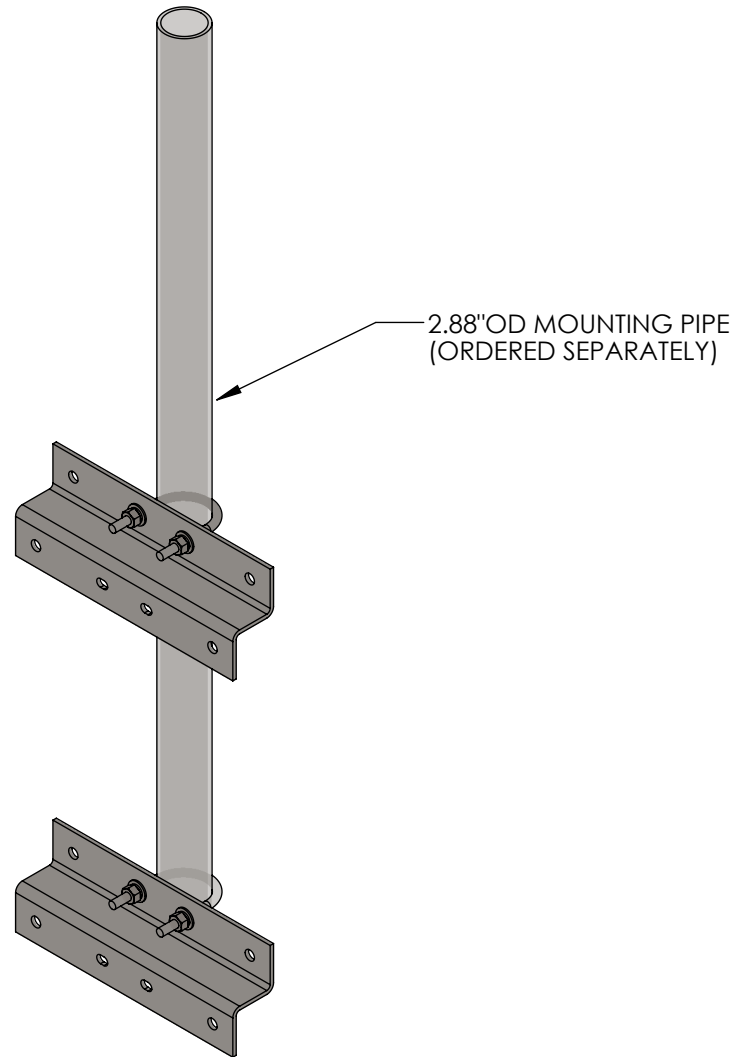

WEIGHT: 20.5 LBS.

PROPRIETARY AND CONFIDENTIAL
 THE INFORMATION CONTAINED IN THIS DRAWING IS THE SOLE PROPERTY OF BAIRD SUPPORTING SYSTEMS. ANY REPRODUCTION IN PART OR AS A WHOLE WITHOUT THE WRITTEN PERMISSION OF BAIRD SUPPORTING SYSTEMS IS PROHIBITED.



WWW.BAIRD MOUNTS.COM

UNLESS OTHERWISE SPECIFIED:
 DIMENSIONS ARE IN INCHES
 TOLERANCES:
 FRACTIONAL ±
 ANGULAR: MACH ± BEND ±
 TWO PLACE DECIMAL ±
 THREE PLACE DECIMAL ±

DO NOT SCALE DRAWING

BAIRD MOUNTING SYSTEMS

WATERLOO, IA 50703
 PHONE: 319-233-3561
 SALES@BAIRD MOUNTS.COM

TITLE:
 ANGLE WALL MOUNT, 3" OFFSET,
 FOR 2.88" OD MAST

DRAWN BY JK	DATE 11/16/14	
MATERIAL STEEL	FINISH HDG	
DWG. PURPOSE CUSTOMER	SHEET 1 OF 2	SCALE -
PART. NO. AWM-3OS16-288		
DWG. NO. AWM-3OS16-288		

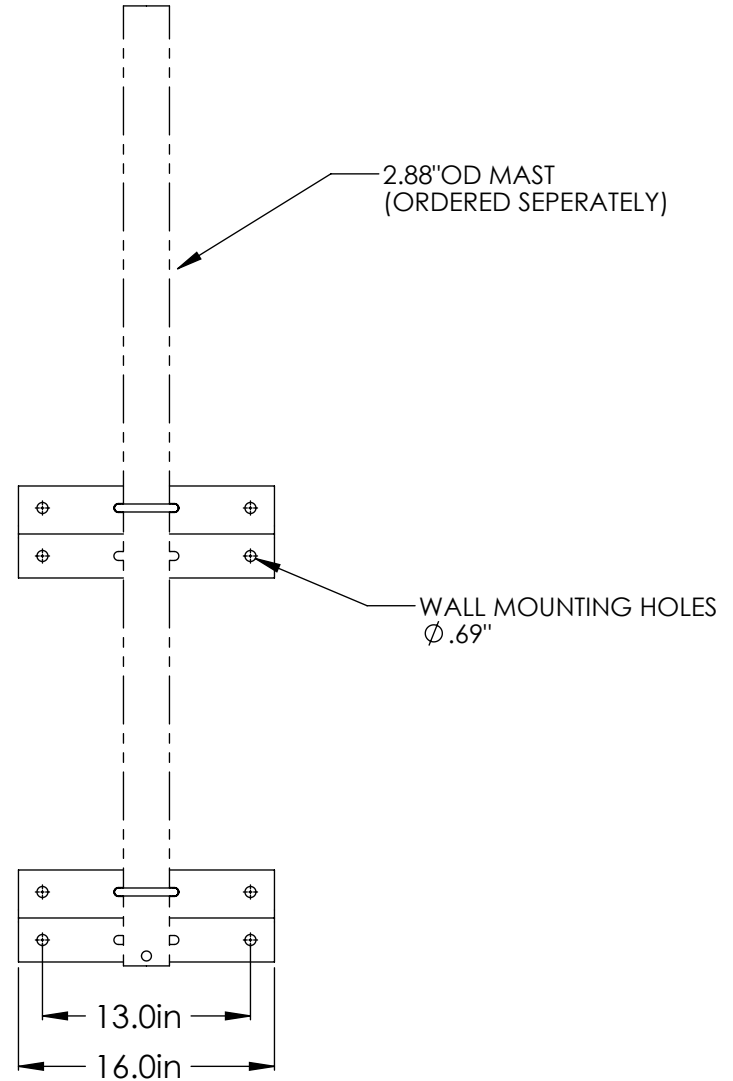
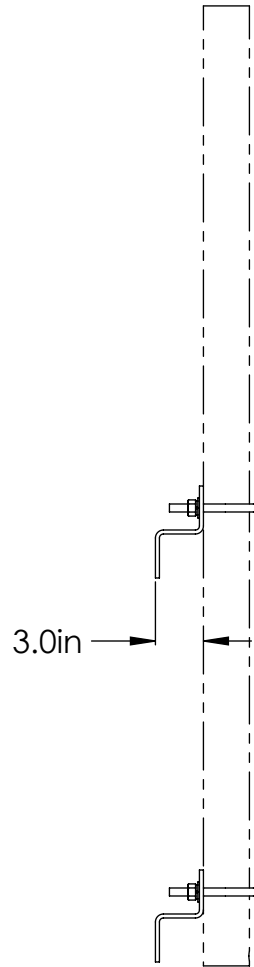

PROPRIETARY AND CONFIDENTIAL

THE INFORMATION CONTAINED IN THIS DRAWING IS THE SOLE PROPERTY OF BAIRD SUPPORTING SYSTEMS. ANY REPRODUCTION IN PART OR AS A WHOLE WITHOUT THE WRITTEN PERMISSION OF BAIRD SUPPORTING SYSTEMS IS PROHIBITED.



WWW.BAIRD MOUNTS.COM

UNLESS OTHERWISE SPECIFIED:

DIMENSIONS ARE IN INCHES
TOLERANCES:
FRACTIONAL ±
ANGULAR: MACH ± BEND ±
TWO PLACE DECIMAL ±
THREE PLACE DECIMAL ±

DO NOT SCALE DRAWING

BAIRD MOUNTING SYSTEMS

WATERLOO, IA 50703
PHONE: 319-233-3561
SALES@BAIRD MOUNTS.COM

TITLE:
ANGLE WALL MOUNT, 3"OFFSET,
FOR 2.88"OD MAST

DRAWN BY JK	DATE 11/16/14	
MATERIAL STEEL	FINISH HDG	
DWG. PURPOSE CUSTOMER	SHEET 2OF2	SCALE -
PART. NO. AWM-3OS16-288		
DWG. NO. AWM-3OS16-288		